

1700ESL Kamvalok[®] Coupler

OPW Transport Series Dry Disconnect Couplings are considered the standard of the industry. For use on multi-compartment petroleum, solvent and chemical product delivery trucks with an on-board pumping unit.

BENEFITS

- Spill Protection** – Helps to reduce the hazards involved in the connection/disconnection process of transferring hazardous materials.
- Provides For Total Closed-Loop Loading Capabilities** – Keeps hazardous liquids and vapors in-line and out of the environment.
- Dual Protection** – OPW Kamvaloks[®] provide automatic closure from both directions – the coupler and the adaptor.
- Autolok™ Locking Arms** – Provide added protection with an automatic locking mechanism signaled by a positive click. Uncoupling requires only an easy tug on the lock release.
- SST Locking Lever Assembly** – Locks in both the opened and closed positions to prevent accidental release or uncoupling.
- Ease of Use** – Built-in elbow swivel and simple connection and disconnection design provides freedom of movement and smooth operation.



1700ESL
 Transport Series
 Dry Disconnect
 Couplings

ORDERING GUIDE

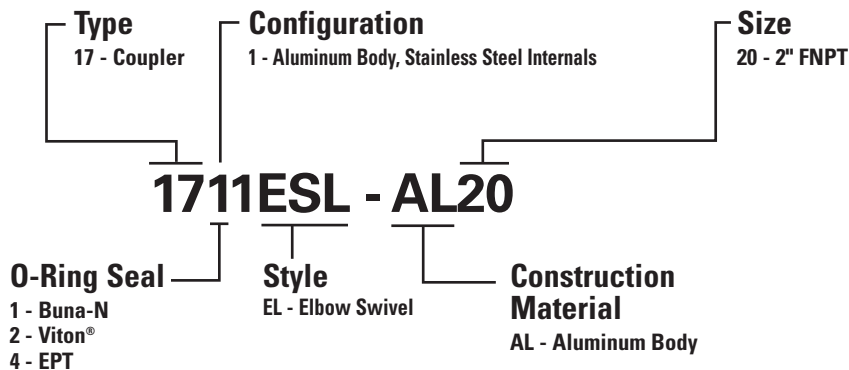

DESIGN PARAMETERS

Design Standard	Size	ASME B31.3
Max. Design Temp	2"	200° F (93° C)
Min. Design Temp	2"	-20° F (-29° C)
Max. Design Pressure	2"	150 PSI (10.5 BAR)

Call OPW Customer Service at 800-547-9393 for complete ordering information.

MATERIALS

Materials	Aluminum (250°F /121°C)
Body, Poppet	A356-T6 ASTM B-26
Cam Arms	ASTM A351 CF8M 316 SST
Seal Cylinder	6061-T6
Shaft	ASTM A479 Ferralium 255 SST
Seals	See Chart
Poppet Link	A351 CD4MCU Duplex SST
Shaft Link	A351 CD4MCU Duplex SST

Seal Options	Repair Kit	Temperature Rating
Buna-N1500	1711ERKL-0020	-20° F – 212° F (-29° C – 100° C)
Fluorocarbon	1712ERKL-0020	-20° F – 400° F (-29° C – 204° C)
EPDM E692	1714ERKL-0020	-50° F – 250° F (-46° C – 121° C)

PART NUMBERS

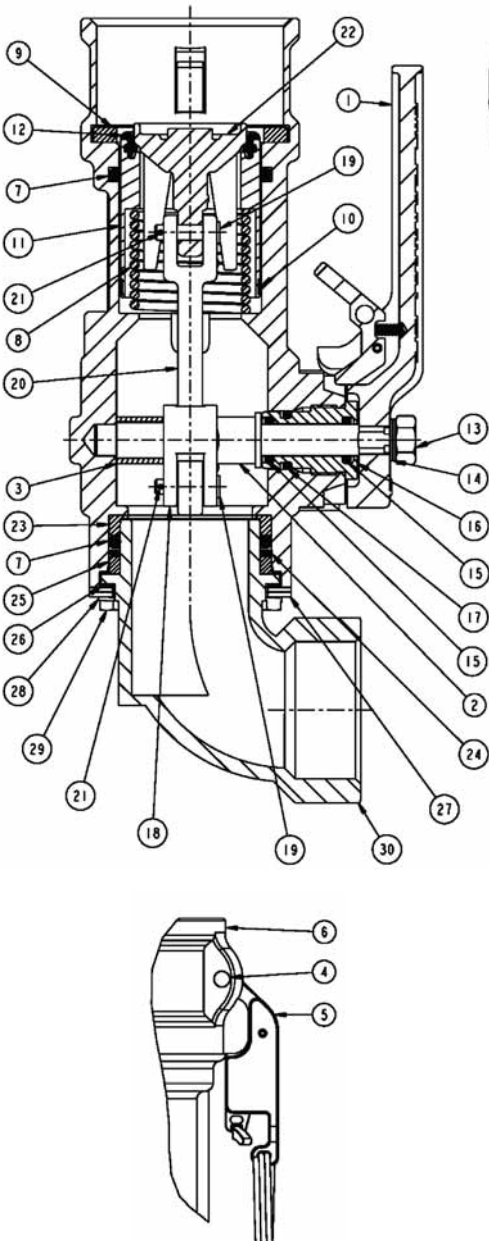

#	Description	Qty	1711ESL	1712ESL	1714ESL	RK
1	Lever Assembly	1	H32040	H32040	H32040	
2	Shaft	1	C21123RE	C21123RE	C21123RE	
3	Spacer	1	H32030RE	H32030RE	H32030RE	
4	Groove Pin, Cam Arm	2	H20141M	H20141M	H20141M	
5	Autlok Arm Assy	1	733ARK-SS20	733ARK-SS20	733ARK-SS20	
6	Body	1	C21131A	C21131A	C21131A	
7	O-Ring, Main Seal	2	H06223M	H01076M	H06142M	+
8	Spring	1	H04328M	H04328M	H04328M	
9	Gasket	1	H20545M	H00974M	H20537M	+
10	Guide, Seal Cylinder	1	H31540M	H31540M	H31540M	+
11	Seal Cylinder	1	H31543A	H31543A	H31543A	+
12	Nose Seal	1	H31528M	H31531M	H31534M	+
13	Nut, Shaft	1	H32111M	H32111M	H32111M	
14	Lock Washer Shaft	1	H31920M	H31920M	H31920M	
15	O-Ring, Shaft	2	H20129M	H20175M	H20176M	+
16	StuffingBox	1	C20812RE	C20812RE	C20812RE	
17	O-Ring, Stuffingbox	1	H31705M	H31706M	H31707M	+
18	Shaft Link	1	9C21125EW	9C21125EW	9C21125EW	
19	Clevis Pin	2	H31692M	H31692M	H31692M	
20	Poppet Link	1	9C21124EW	9C21124EW	9C21124EW	
21	Cotter Pin	2	H04981M	H04981M	H04981M	+
22	Poppet	1	C21129A	C21129A	C21129A	
23	Bearing	1	H05096M	H05096M	H05096M	+
24	Back Up Ring	1	H05155M	HJ0617M	HY91574	+
25	Bearing	1	H05097M	H05097M	H05097M	+
26	Washer	1	H05100M	H05100M	H05100M	+
27	Flange	4	H05095RS	H05095RS	H05095RS	
28	Lock Washer	4	H20441M	H20441M	H20441M	
29	Screw	4	H03657M	H03657M	H03657M	
30	Elbow	1	C01345A	C01345A	C01345A	

+Items included in repair kits

IMPORTANT: OPW products should be used in compliance with applicable federal, state, provincial, and local laws and regulations. Product selection should be based on physical specifications and limitations and compatibility with the environment and materials to be handled. OPW MAKES NO WARRANTY OF FITNESS FOR A PARTICULAR USE. All illustrations and specifications in this literature are based on the latest product information available at the time of publication. OPW reserves the right to make changes at any time in prices, materials, specifications and models and to discontinue models without notice or obligation.

MAINTENANCE

2"	O-Ring, Main Seal	Gasket	Nose Seal	O-Ring, Shaft	O-Ring, Stuffingbox
Buna-N1500	H06223M	H20545M	H31528M	H20129M	H31705M
Fluorocarbon	H01076M	H00974M	H31531M	H20175M	H31706M
EPDM	H06142M	H20537M	H31534M	H20176M	H31707M



Installation Preparations: Read & understand these instructions before starting installation or dismantling:

- Coupler to be used for its designated purpose only
- Local regulations for (un)loading must be followed at all times
- Product flow may result in static electricity; grounding of equipment is required
- OPW instructions must be followed for installation or dismantling at all times
- **Make sure to use adequate personal protection at all times during operation**
- Secure whatever device Coupler will be mounted to (e.g. Loading Arm, hose, etc.)
- Thread coupler onto pipe (use proper thread sealant)



Caution: All OPW products have literature that indicates the maximum service conditions for the unit. This information must be reviewed prior to installation and start-up. If there is any doubt of applicability for operation in a system under actual service conditions, consult the factory before placing in service.



Caution: Do not attempt any maintenance/ service while the equipment is in operation. System pressure must be relieved and the product drained before attempting any service on the unit. The line must be locked out while service is in progress. Read the operating instructions in the maintenance manual before using or servicing this product. Failure to do so could result in serious personal injury, property damage or product failure.

MAINTENANCE



Attention: The same risks and procedures of initial installation apply.



Specific Warnings:

- Remove pressure from the system before attempting to remove coupler
- Secure piping before attempting to remove coupler



Consider the following when servicing the Coupler:

- When Coupler is over-pressurized, it must be inspected thoroughly
- After maintenance is performed, it must be tested before the next use (see Testing After Servicing)
- Periodic inspection (every 3 months) for leakages (especially with toxic or hazardous mediums)
- Maintenance must be performed by authorized personnel
- Periodic maintenance (once a year) is required according to the maintenance instructions
- In case of (parts of) couplers being redirected, the initiator must provide information about the mediums, which have been in contact with (parts of) the coupler
- During maintenance (partial) dismantling could be necessary, the same risks and procedures apply



Caution: Do not drop OPW products onto hard surfaces. Chipping and deformation of the product may occur. Repeated mishandling of the product could result in personal injury, property damage or product failure.



Warning: OPW products do not eliminate possible exposure to hazardous substances. The conditions of handling and use are beyond our control, and we make no guarantee and assume no liability for damages or injuries related to the use of our products. Follow the safety precautions outlined in the Material Safety Data Sheets for the material being used. It is the responsibility of the user to comply with all federal, state and local regulations. Always employ proper safety precautions and handling techniques. Failure to do so could result in serious personal injury, property damage or product failure.



Warning: Proper seal and wetted material part selection is critical for safe operation. To assure maximum life for the service intended, use only those materials compatible with the fluids being handled. Please note material being supplied and make certain that it is suited for the intended service. Failure to do so could result in serious personal injury, property damage or product failure.

DETAILED DISASSEMBLY *(for seal replacement)*

Recommended Tools: Adaptor body of OPW Kamvalok® Adaptor, Flat Head Screwdriver, 17mm and 1-1/4" Driver and Torque Wrench

Warning: Verify what kind of medium is loaded with this Coupler reading the manuals provided. When the medium is nuclear, hazardous or toxic, one is obligated to clean parts with the help of specialized personnel, companies or governments.

Step 1:

- Remove coupler from piping or hose
- Remove (4) bolts, (4) lock washers, (4) flanges and washer
- Remove elbow, bearing, back-up ring, main seal O-ring and bearing



Step 2:

- Install adaptor and close Autolok™ arms
- Depress release latch and rotate lever only part of the way
- Do not rotate the lever into the fully opened position
- The adaptor is only in place to take the pressure off of the poppet



Warning: With the release latch depressed, the operating lever is unlocked and can rotate. Do not unlock or apply pressure to the lever unless you are trying to open the valve. Use caution when working around the lever when the system is under pressure. Once the lever starts moving pressure can cause it to rotate violently. Under pressure, poppet will cause lever to rotate violently if not restrained.

Step 3:

- Remove shaft nut and lock washer from top of lever assembly
- Remove lever assembly from shaft
- Unthread stuff box and pull out shaft
- Pull stuff box off of shaft and remove the 3 o-rings from it
- Remove spacer from the shaft



Warning: Use caution when performing this next step

Step 4:

- While pressing the adaptor into the body release the Autolok™ arms
- Slowly allow the adaptor, poppet & seal cylinder assembly to spring out of the body
- Once all spring pressure is relieved you can remove the adaptor
- Remove the poppet assembly, followed by the seal cylinder and spring



IMPORTANT: OPW products should be used in compliance with applicable federal, state, provincial, and local laws and regulations. Product selection should be based on physical specifications and limitations and compatibility with the environment and materials to be handled. OPW MAKES NO WARRANTY OF FITNESS FOR A PARTICULAR USE. All illustrations and specifications in this literature are based on the latest product information available at the time of publication. OPW reserves the right to make changes at any time in prices, materials, specifications and models and to discontinue models without notice or obligation.

Step 5:

- Remove the seals from the seal cylinder
- Remove the seals from inside the coupler body
- Be careful not to scratch the sealing surfaces of the coupler body



Disassembly Complete:

- Clean and inspect all sealing surfaces after removing seals
- Install new seals and reassemble coupler

DETAILED REBUILD

Step 1:

- Clean and inspect all sealing surfaces after removing seals
- Install new seals and reassemble coupler
- Lubricate O-rings with proper grease and fit into the grooves in the stuffbox
- Lubricate stuffbox threads
- Fit new O-rings into the grooves in the stuff box



Step 2:

- Carefully fit nose seal into seal cylinder and slightly expand sleeve bearing and fit into outer groove on seal cylinder
- Run finger over inside mating surface between nose seal and body to check for any uneven seating. If any raised edges exist remove nose seal and reset more evenly



Step 3:

- Fit O-ring and gasket into body
- Gasket should be compressed slightly and allowed to spring into its groove

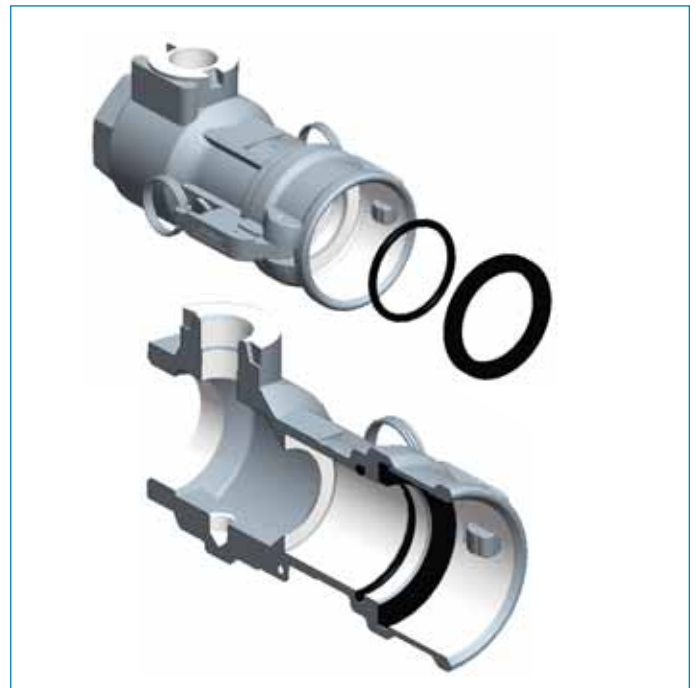

Step 4:

- With coupler body in a vertical position, insert cylinder spring & seal cylinder, using the adaptor body to compress the spring and push all components into the body
- Use caution not to disturb the O-ring already installed in the body when working the seal cylinder into the opening
- Open the Autolok™ arms to allow the adaptor to fully seat in the coupler body
- Once the adaptor is fully seated, lock adaptor into body by closing Autolok™ handles



Step 6:

- Insert spacer through threaded end of the coupler
- Insert shaft through stuffingbox hole in coupler body
- Insert shaft through shaft link, aligning flats on shaft with flats on shaft link
- Insert shaft through spacer and into hole in bottom of coupler body
- When installed, the shaft and poppet linkage assembly should be oriented as shown

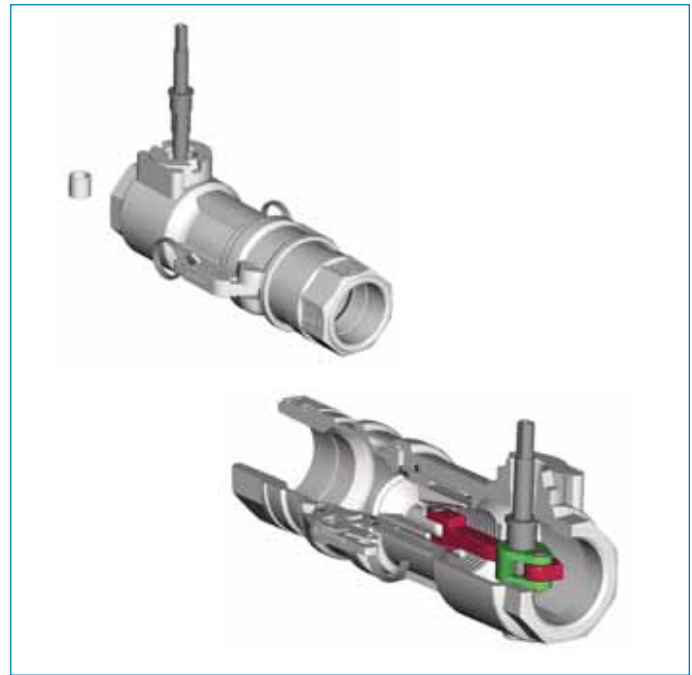

Step 5:

- Insert poppet linkage assembly through adaptor with cast "dots" on linkage components facing up towards stuffingbox area of coupler body

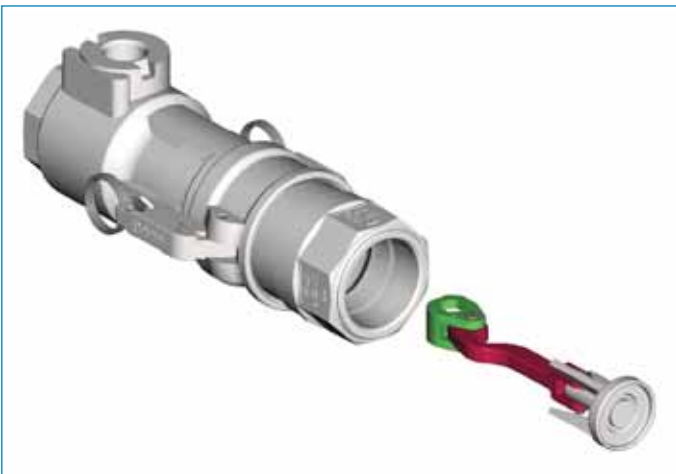

Step 7:

- Turn the shaft 90 degrees from the closed position to relieve the spring pressure on the linkage
- Install stuffingbox over shaft and thread down with a wrench until it is tight
- Using a torque wrench tighten the stuffingbox to 960 inch-lbs (108 Newton-Meters)
- Remove the adaptor from the coupler



IMPORTANT: OPW products should be used in compliance with applicable federal, state, provincial, and local laws and regulations. Product selection should be based on physical specifications and limitations and compatibility with the environment and materials to be handled. OPW MAKES NO WARRANTY OF FITNESS FOR A PARTICULAR USE. All illustrations and specifications in this literature are based on the latest product information available at the time of publication. OPW reserves the right to make changes at any time in prices, materials, specifications and models and to discontinue models without notice or obligation.

Step 8:

- With the poppet in the outward position, install the handle as shown
- Secure the lever by threading the flange nut on the shaft
- Tighten the flange nut to a torque of 290 inch-lbs (33 Newton-Meters)



Step 10:

- Rotate the handle into the closed position
- Assembly complete. Reattach coupler to piping.



Step 9:

- Install bearing, lubricated main seal O-ring, back-up ring and bearing
- Install elbow into coupler body
- Install washer, (4) flanges, (4) lock washers and (4) bolts
- Tighten bolts with torque wrench to 65 inch-pounds



Testing After Servicing:

- When servicing has occurred and parts have been replaced, it is necessary to test the Coupler for a safe and secure use.
- Open Autolok™ handles, and bring coupler and adaptor together. Once fully seated, close the Autolok™ handles.





1700ESL Dry Disconnect Couplings



WARNING

Failure to follow these warnings could result in serious personal injury, property damage or product failure.

- 1) Do not attempt any maintenance service while the equipment is in operation. System pressure must be relieved and the product drained before attempting any service on the unit. The line must be locked out while service is in progress. Proper thermal relief must be provided at all times while equipment is in service.
- 2) OPW products do not eliminate possible exposure to hazardous substances. The conditions of handling and use are beyond our control, and we make no guarantee and assume no liability for damages or injuries related to the use of our products. Follow the safety precautions outlined in the Material Safety Data Sheets for the material being used. It is the responsibility of the user to comply with all federal, state and local regulations. Always employ proper safety precautions and handling techniques.
- 3) Proper seal and wetted material part selection is critical for safe operation. To assure maximum life for the service intended, use only those materials compatible with the fluids being handled. Please note material being supplied and make certain that it is suited for the intended service.

opw®

Engineered Systems

PART OF OPW FLUID TRANSFER GROUP

A DOVER COMPANY

2726 Henkle Drive
Lebanon, OH 45036 USA
Telephone: 513-696-1500
Toll Free: 800-547-9393
Fax: 513-932-9845
www.opw-es.com